

PIONEER®



VINTAGES HIFI

**SOLID STATE
FM-AM STEREO RECEIVER**

Model **SX-440**®-W

CAUTION Before connecting the line cord to the wall socket, carefully read and follow the instructions described below, to assure the safety of your unit.

- Model SX-440 is set for 240V operation when shipped. If this unit is used in a different line-voltage area, read and follow "LINE VOLTAGE SELECTION AND FUSE" on back cover. Be sure that the line voltage setting on your unit agrees with the line voltage in your area and that the fuse installed in your unit is a proper one.

INSTALLATION, OPERATING AND SERVICE MANUAL

Including PARTS LIST, CIRCUIT DIAGRAMS, TROUBLE SHOOTING AND MOUNTING TEMPLATE.

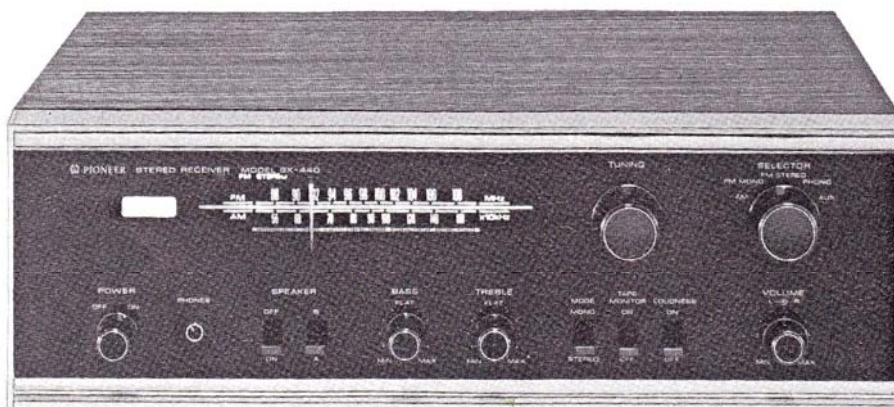

PIONEER ELECTRONIC CORPORATION

PIONEER

FEATURES OF SX-440

●SENSITIVE FM CIRCUIT

A high performance transistor is used in RF amplifier for excellent sensitivity. No distortion or cross modulation will be caused by high input power.

●BUILT-IN MULTIPLEX CIRCUIT

Provides full-frequency response and a good separation between channels for excellent stereo effect.

●AUTOMATIC FM MULTIPLEX SIGNAL INDICATOR

A lamp lights automatically when receiver is tuned to an FM station transmitting stereo multiplex signals.

●EASY-TO-READ TUNING INDICATOR

The clear, easy-to-read Meter permits quick station selection.

●LOUDNESS CONTOUR CIRCUIT

Preserves musical balance and provides full dynamic range of reproduction, even at very low volume control settings.

●INDEPENDENT TONE CONTROLS

Separate bass and treble controls permit adjustment of tonal qualities to suit room acoustics and individual taste.

●FULL COMPLEMENT OF INPUTS

Stereo inputs are provided on the rear panel for record player with a magnetic, ceramic, or crystal cartridge; there are also inputs for a tape recorder or tape deck; plus auxiliary input for TV sound or other sound source.

●TAPE RECORDING OUTPUT

Permits making stereo or monaural tape recording of any program material (AM, FM, FM stereo multiplex, or record) while the material is being played.

●STEREO HEADPHONE JACK

Permits private listening through a stereo headphone without disturbing other people. Located on the front panel for easy access.

● DUAL-CHANNEL HIGH-FIDELITY AUDIO POWER AMPLIFIER

High-efficiency power transistors are employed in the pushpull complementary circuit for each audio amplifier channel for full fidelity frequency response.

LINE VOLTAGE SELECTION AND FUSE

Switching Line Voltage Setting and Fuse

In order to remove the fuse, turn the fuse cap located on the line voltage selector switch in the direction indicated by an arrow. Then remove the fuse plug from the unit. Put the fuse plug back so that the proper line voltage marking can be seen through the cut in the edge of the plug.

Whenever the set position of the selector switch is changed, check the rating of the fuse. A 0.5-ampere fuse is to be used for either 220V or 240V operation and a 1-ampere fuse for any of 110V, 117V, or 130V operation. If the rating of the fuse is proper, install the fuse in the fuse cap.

●REPLACING OF FUSE

When the fuse is blown, remove the fuse cap and replace the fuse with a new one.

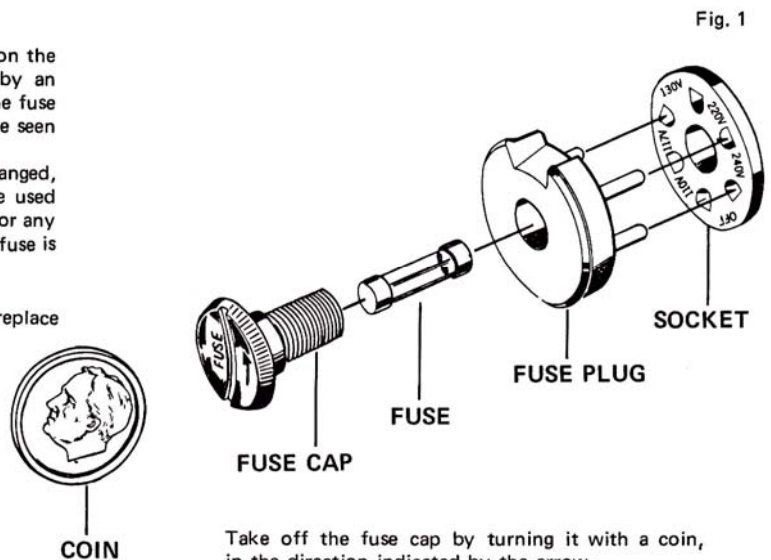

Fig. 1

Take off the fuse cap by turning it with a coin, in the direction indicated by the arrow.

REAR CONNECTIONS

FM OUTDOOR ANTENNA

If the indoor antenna is not adequate for reception of FM programs, separately establish an antenna in the outside of the house for receiving FM signals.

FM INDOOR ANTENNA (furnished with SX-440)

ALL TERMINALS ARE INTERNALLY WIRED AS FOLLOWS:
 TOP TERMINAL—CH. L (Left Channel)
 BOTTOM TERMINAL—CH. R (Right Channel)

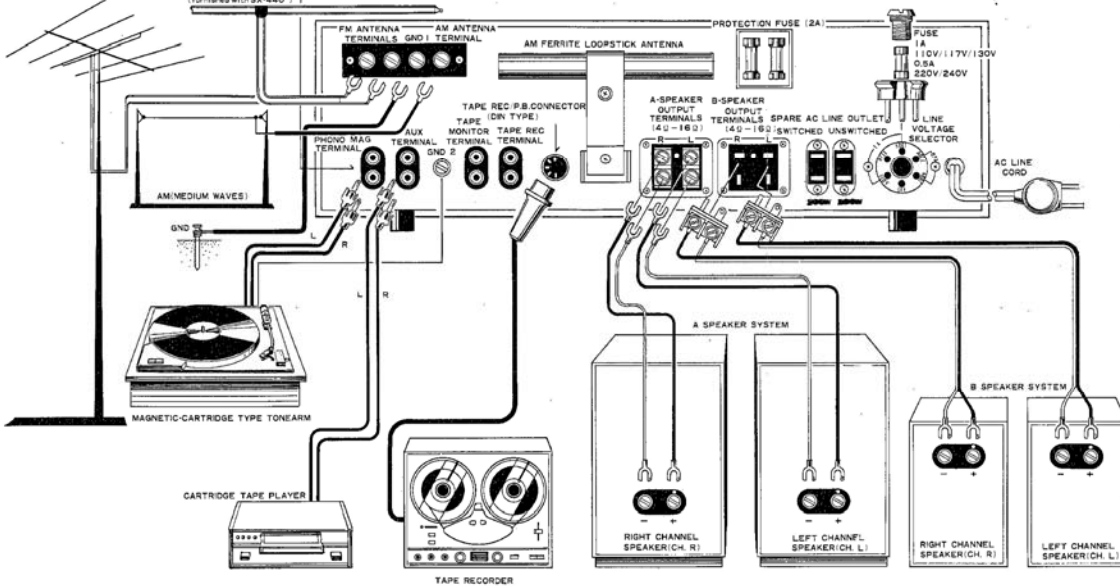

NOTE: If the record/playback connector ("DIN" type) is provided on your tape recorder and is connected to the corresponding TAPE REC./P.B. CONNECTION on this receiver, separate connection of the record and MONITOR terminals to the receiver is not needed.

NOTE: 1. When only one set of speaker system is connected to the SX-440, the speaker impedance may be 4 to 16 ohms.
 2. Do not short the speaker terminals.

Fig. 2

STEREO SYSTEM

The SX-440 is a general-purpose stereo amplifier. Connect to it the loudspeaker systems (two or four), record player, tape recorder, etc., which are separately available.

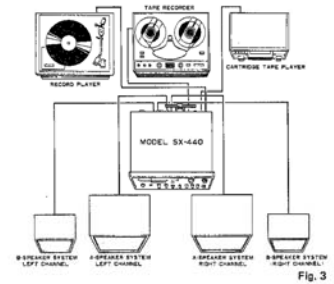

Fig. 3

INSTALLATION

For installation of the stereo system, select a place meeting the following:

- Well ventilated, and free from moisture and dust
- Unexposed to direct sunlight
- Afer from heat radiators (space heaters, etc.)
- Stable without incurring vibrations

LISTENING ROOM

- When the stereo system is installed, listen to music according to the connection and operation instructions described below.
- The reproduced sound is very different depending on the size of the room, the furniture arrangement in the room, and the materials of walls, floor and ceiling. Generally, the reproduced sound fills the room if the room has a low ceiling and hard floor, or the room has a small length and a hard wall opposing loudspeakers. This undesirable acoustic condition can be much alleviated by laying a carpet on the floor for the former room and by covering the wall with a thick curtain for the latter room. It is also an effective solution to change the arrangement of furniture for irregular reflection of the loudspeaker sound.

PIONEER

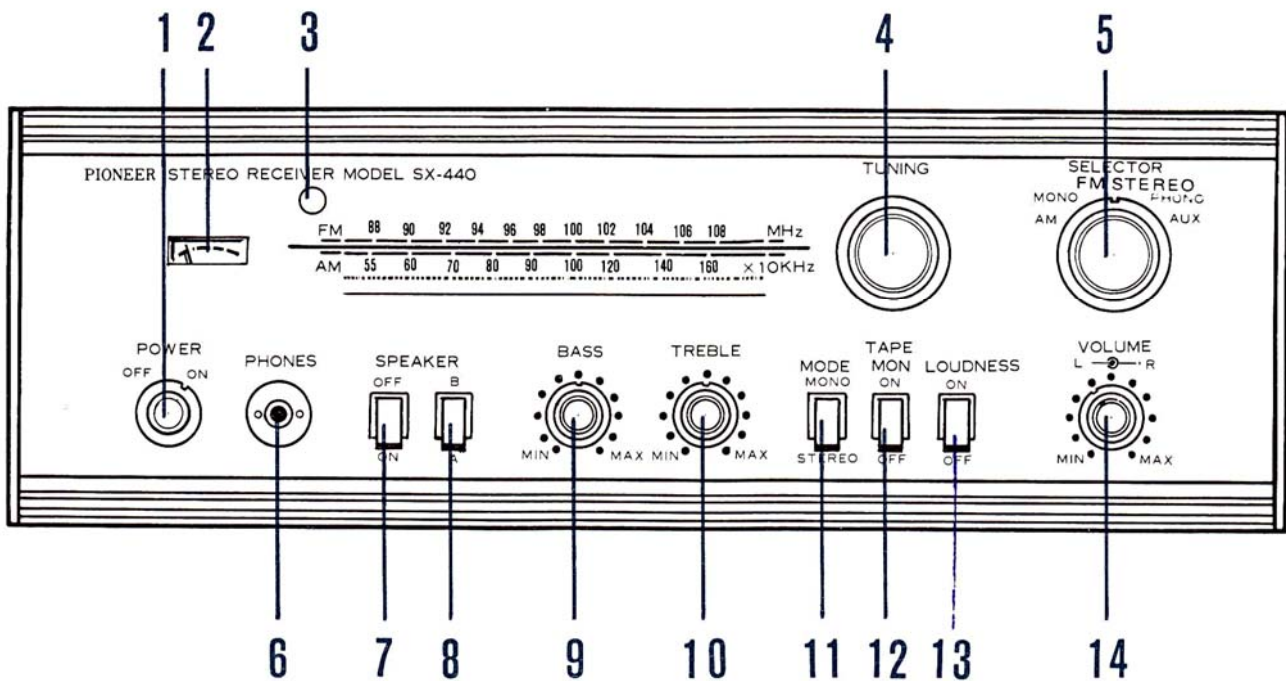

Fig. 4

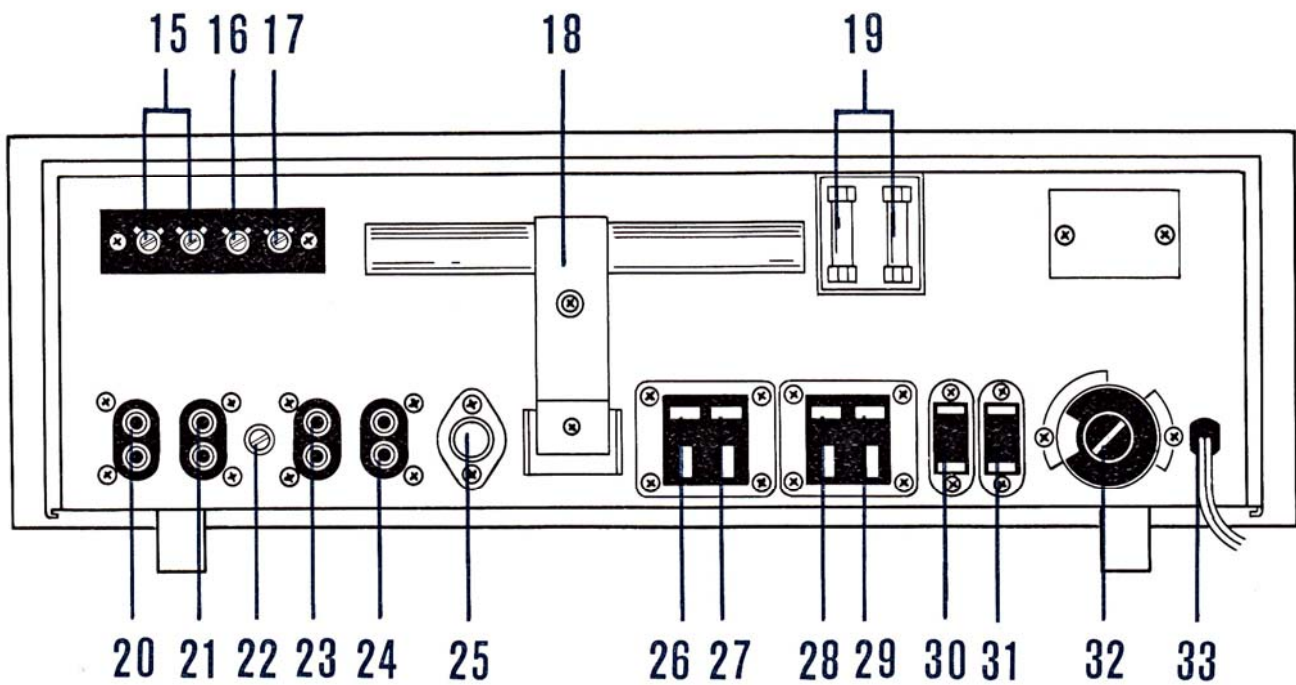

Fig. 5

KNOBBS AND SWITCHES ON FRONT PANEL

1. POWER SWITCH

Power is turned on when the switch is rotated clockwise; turned off when rotated counterclockwise. Operation of this switch also turns on and off the power supplied to the AC OUTLET (30) located on the rear panel of the SX-440.

2. TUNING INDICATOR

When tuning the radio receiver to an FM or AM broadcast station, the TUNING KNOB (4) is adjusted so that the pointer of this meter may deflect to the maximum.

3. FM STEREO INDICATOR

When the SX-440 receives an FM stereo program, this lamp lights.

4. TUNING KNOB

An AM or FM broadcasting station is tuned in. While observing the pointer of the TUNING INDICATOR (2), set the knob for the best receiving condition.

5. SELECTOR SWITCH

The SX-440 is set for one of the following operations:

AM Reception of AM broadcasts
 FM MONO . . . Reception of monaural FM broadcasts
 FM STEREO . . Automatically selective reception of stereo or monaural FM broadcasts
 PHONO Play of disk record
 AUX Connection of a record player having a crystal or ceramic pickup, cartridge tape player, or audio output of a TV receiver.

6. PHONES

Cord plug of a stereo headphone is inserted here for enjoying stereo play without disturbing other people around. Loudspeakers stop emitting sound then. For the stereo headphone, PIONEER's Model SE-2P, SE-20, SE-30 or SE-50 is recommended.

• When a longer cord is required for the stereo headphone, use PIONEER's Model JB-23 extension cord separately available.

When desiring to connect two stereo headphones, use PIONEER's Model JB-22 "Y" cord separately available.

7. LOUDSPEAKER ON/OFF SWITCH

With this switch in the "ON" position, loudspeakers emit sound. When the switch lever is set to "OFF", loudspeakers stop sounding. It is convenient for using a headphone.

8. LOUDSPEAKER SELECTOR SWITCH

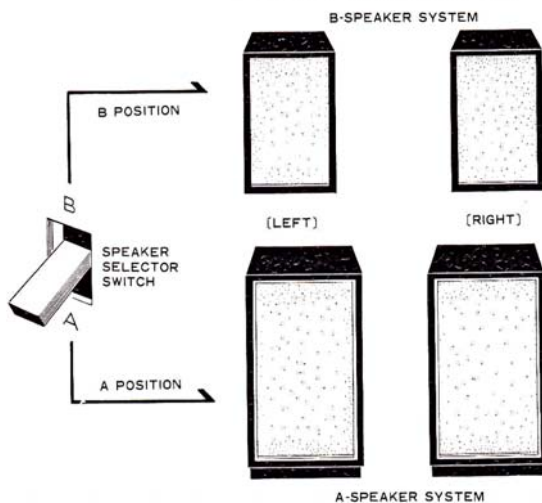

Fig. 6

When the switch is set to the "A" position, the loudspeakers connected to the SPEAKER SYSTEM A TERMINALS on the rear panel of the SX-440 emit sound; when set to "B", those connected to the SPEAKER SYSTEM B TERMINALS.

9. BASS CONTROL

As this knob is turned clockwise, bass is boosted, as turned counterclockwise, attenuated. The control is designed to give a flat characteristic curve when the knob is set to the middle of the rotation range.

• This knob controls the tone quality of both right and left channels simultaneously.

10. TREBLE CONTROL

Use of this treble control knob is similar to that of the BASS CONTROL KNOB (9).

11. MODE SWITCH

When playing a disk record or tape, or receiving a broadcast program, keep this switch in the "STEREO" position. Set the switch to "MONO" only when using a monaural record player or tape recorder, or reproducing a tape on which monaural recording is made.

12. TAPE MONITOR SWITCH

For ordinary record play or radio reception, keep this switch in the "OFF" position.

Set the switch to "ON" only when playing back a tape by using a tape recorder (or tape deck) or monitoring the recording condition of such equipment. If the switch is set to the "ON" position when conducting disk record play or radio reception, loudspeakers do not sound. Be careful in this respect.

13. LOUDNESS CONTOUR SWITCH

When the switch is set to the "ON" position while the SX-440 is operated at a low sound volume, both bass and treble are boosted for easy listening. When the equipment is operated at a high sound volume, it is recommended to keep the switch in the "OFF" position.

14. VOLUME CONTROL

The loudspeaker sound volume increases when this knob is turned clockwise; it decreases when the knob is rotated counterclockwise. This double knob consists of two component knobs interlocked by friction. When the knob is turned, both component knobs rotate together to control the sound volumes of right and left channels simultaneously. To adjust the volume of either right or left channel alone, hold one of the component knobs by one hand and turn the other component knob by the other hand. It is convenient for balancing the sound volumes of both channels. The front knob is for the left channel and the rear knob is for the right channel.

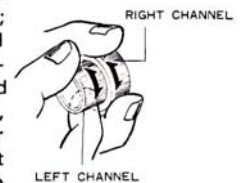

Fig. 7



TERMINALS AND CONNECTION ON REAR PANEL

15. FM ANTENNA TERMINALS

An FM broadcast receiving antenna will be connected to these terminals.

16. GROUND TERMINAL 1

Connect a ground conductor to this terminal for grounding the SX-440

17. AM ANTENNA TERMINAL

This terminal is provided for connecting an external AM broadcast receiving antenna.

NOTE: For the most suitable FM antenna, AM antenna and grounding, refer to the article "ANTENNA CONNECTION AND GROUNDING".

18. AM FERRITE ANTENNA

An AM broadcast receiving antenna accessory to the SX-440. When using the SX-440 where the field intensity is high, reception can be conducted simply by adjusting the direction of this antenna without connecting an external antenna to the AM ANTENNA TERMINAL (17).

19. PROTECTIVE FUSES

These fuses protect transistors in the SX-440. When loudspeaker terminals are short-circuited, or the SELECTOR (5) on the front panel is operated while the SX-440 is used at a high sound volume, one or both of the fuses may be blown to protect power transistors. When this occurs, replace the blown fuses with the accessory 2-ampere fuses. The right-hand side fuse is for the left channel; the left-hand side fuse is for the right channel.

20. MAGNETIC PHONO TERMINALS

Connect here the output cords of a record player equipped with a magnetic cartridge. The upper jack is for the left channel; the lower jack, for the right channel. When connecting a monaural record player, use either one of the jacks.

21. AUXILIARY TERMINALS

These jacks are used when connecting the output cords of a record player equipped with a crystal or ceramic cartridge, or a cartridge tape player. Also use these jacks for reproducing the audio output of a TV receiver. The upper jack is for the left channel; the lower jack, for the right channel.

22. GROUND TERMINAL 2

If the record player or other equipment to be used with the SX-440 has a ground conductor, connect it to this terminal.

23. TAPE MONITOR TERMINALS

Connect to these jacks the playback output terminals (line output) or monitor terminals of the tape recorder (or tape deck) used with the SX-440.

24. TAPE RECORDING TERMINALS

Connect to these jacks the recording input terminals (line input) of the tape recorder (or tape deck). The signals outgoing from these terminals cannot be adjusted with the VOLUME (14), BASS (9) or TREBLE (10) controls.

NOTE: For correct connection to the TAPE MONITOR (23) and TAPE RECORDING (24) jacks, refer to the article "CONNECTION OF TAPE RECORDER"

25. TAPE RECORDING / PLAYBACK CONNECTOR (DIN TYPE)

Provided that the tape recorder (or tape deck) to be used has a DIN-type tape recording/playback connector, connection for recording and playback (and monitor) can be completed simply by linking the tape recorder with the SX-440 through the recording/playback cord that is separately available. When this connector is used, terminals (23) and (24) are not used.

26 & 27. SPEAKER SYSTEM A TERMINALS

Two speaker systems A and B can be connected to the SX-440, and they can be selectively used by operating the switch (8). Connect the right channel loudspeaker of the first speaker systems to terminals (26) and the left channel loudspeaker to terminals (27).

28 & 29. SPEAKER SYSTEM B TERMINALS

When using two speaker systems, use these terminals (28) and (29) for the second systems. Connect the loudspeaker for the right channel to terminals (28) and those for the left channel to terminals (29).

NOTE: For connection of loudspeakers to these terminals, the plugs contained in the accessory bag must be used. For correct loudspeaker connection, refer to the article "CONNECTION OF LOUDSPEAKER SYSTEMS".

30. AC OUTLET (SWITCHED)

The power obtained from this AC outlet is turned ON and OFF interlinked with the operation of POWER SWITCH (1). A maximum of 200 VA can be supplied to the record player or other equipment connected.

31. AC OUTLET (UNSWITCHED)

An AC outlet having a capacity of 200 VA. This power outlet is not interlinked with the operation of POWER SWITCH (1).

32. LINE VOLTAGE SELECTOR AND FUSE HOLDER

This selector is used for setting the SX-440 to suit the line voltage to be supplied. It also serves as a fuse holder. For the selector setting and fuse replacement procedures, refer to the article "LINE VOLTAGE SELECTION AND FUSE". (Page 1)

33. AC CORD

After correctly setting the LINE VOLTAGE SELECTOR (32), connect this cord to an outlet of the commercial power line.

CONNECTION OF LOUDSPEAKER SYSTEMS

- When connecting loudspeakers, extract speaker connector plug from the accessory bag and connect the speaker wire leads to the plugs and illustrated below. Be sure to connect the positive of the leads to the positive terminal of the plug.
- When the loudspeakers are connected to the plugs, insert the right channel speaker plug into the speaker system A terminal socket (26) and the left channel speaker plug into the speaker system A terminal socket (27). (Refer to the connection diagram shown in page 2.)
- When using two speaker systems, connect the wire leads of the second speaker systems to speaker plugs as described above, and insert the right channel speaker plug of this speaker system into the speaker system B terminal socket (28) and the left channel speaker plug into the speaker system B terminal socket (29).

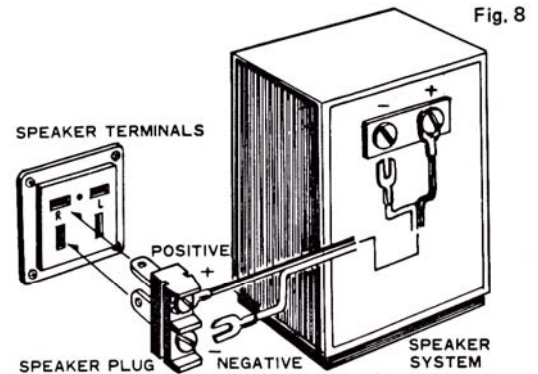

ANTENNA CONNECTION AND GROUNDING

■ FM BROADCAST RECEIVING ANTENNA:

The field strength of FM broadcast is much attenuated behind mountains and buildings, and in ferroconcrete buildings. This requires to use an FM antenna of different type depending on the area and place where the SX-440 will be used. Use the most suitable antenna, referring to the following:

- Employ the T-type indoor antenna accessory to the SX-440 when using the SX-440 within a wooden building near the FM radio station. Connect the end of the vertical section of the T-type antenna to the FM ANTENNA TERMINALS (15) as shown in Fig. 9, and expand the horizontal section of the T-type antenna. While actually receiving broadcast, determine the direction of the horizontal section for the best radio reception and fix it on a wall or other place. Refer to the article "RECEPTION OF FM BROADCAST" regarding the determination of the antenna direction.
- When using the SX-440 afar from the broadcasting station, behind a mountain or within a ferroconcrete building, install an FM radio antenna (or FM/TV common antenna) outdoors and connect it to the FM antenna terminals (15). The FM antenna is various in type, having 3 to 7 elements. Select the most suitable antenna by consulting a nearby radio antenna sales store.

NOTE: The installation procedure of FM radio antenna is similar to that of TV antennas. For details, follow the instructions accompanying the FM radio antenna purchased.

■ AM BROADCAST RECEIVING ANTENNA:

- When using the SX-440 near the broadcasting station or inside a wooden building, it is unnecessary to install an AM antenna. In such an area, set the direction of the AM FERRITE ANTENNA for the best radio reception while actually listening to broadcasts. Refer to the article "RECEPTION OF BROADCAST".
- If good reception cannot be attained even by properly adjusting the direction of the AM FERRITE ANTENNA, use the accessory AM lead wire antenna. Connect one end of the antenna to the AM ANTENNA TERMINAL (17) and expand the wire along a wall of the room.
- If good reception cannot be attained even when the accessory lead wire antenna is used, install an AM antenna outdoors. Connect the lead-in wire of the outdoor antenna to the AM ANTENNA TERMINAL (17).

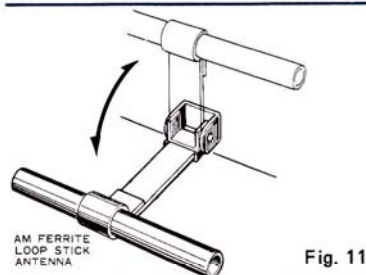
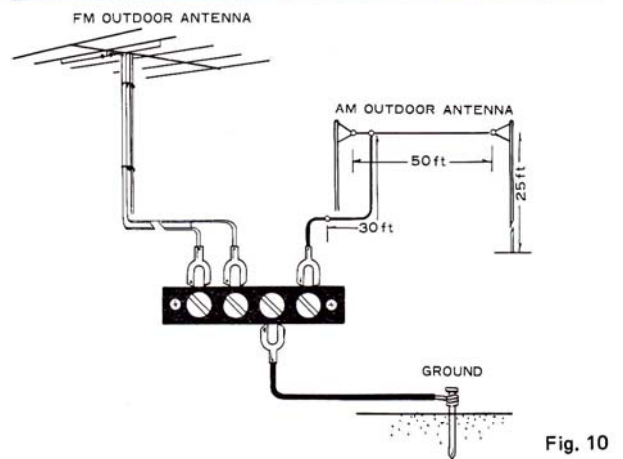
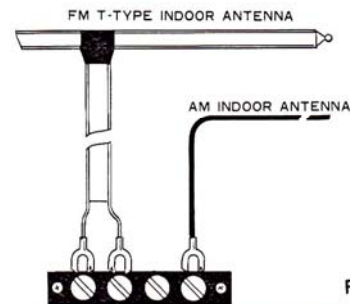



NOTE: For the outdoor antenna, a standard AM broadcast antenna can be formed by purchasing PVC wire from an electric appliance shop and installing it 25 feet (7.5 m) above the ground for a horizontal length of 50 feet (15 m), with a feeder line 30 feet (10 m) long. These wire lengths may not be so precise and may be as long as allowed by the place of installation. However, the height of the horizontal section of the antenna should not be too low to attain a good antenna effect.

■ GROUNDING:

- Grounding or non-grounding the GROUND TERMINAL 1 (16) does not much affect the performance of the SX-440. However, it is desirable to ground the terminal from the viewpoint of safety.
- Connect to the GROUND TERMINAL 1 (16) the ground conductor leading to the earth.

CONNECTION OF RECORD PLAYER

- If the record player to be used with the SX-440 has a magnetic cartridge, connect the output cords of the record player to the MAGNETIC PHONO TERMINALS (20); if the record player has a crystal or ceramic cartridge, connect the output cords to the auxiliary terminals. Insert the output cord plug for the left channel into the upper terminal jack, and that for the right channel into the lower terminal jack.

When using a monaural record player, connect its output cord to the upper (left channel) terminal.

NOTE: If the output cord plug of the record player to be connected does not fit the input terminal jack of the SX-440, replace the plug with the pin plug contained in the accessory bag.

CONNECTION OF TAPE RECORDER (OR TAPE DECK)

- The tape recorder to be used with the SX-440 should have an output terminal (line output) for connection to external amplifier, or a tape monitor terminal.
- When using a tape deck, the tape deck should have a recording/playback preamplifier built in. PIONEER's Model T-500F separately available can be used with the SX-440 without any problems.

■ CONNECTION FOR PLAYBACK (OR TAPE RECORDING MONITOR):

Connect the playback output terminals (line output or tape monitor terminals) of the tape recorder (or tape deck) to the TAPE MONITOR TERMINALS (23). The connecting procedure is similar to that of the above "CONNECTION FOR RECORDING".

■ CONNECTION FOR RECORDING:

Connect the recording input terminals (line input) of the tape recorder (or tape deck) to the TAPE RECORDING TERMINALS (24) of the SX-440. For this connection, use the cords which are normally accessory to the tape recorder.

The upper one of the recording input terminals (line input) is for the left channel; the lower one, for the right channel. When the tape recorder is monaural, connect its input terminal to the upper TAPE RECORDING TERMINAL (24).

■ USE OF TAPE REC/P.B. CONNECTOR:

If the tape recorder (or tape deck) to be connected to the SX-440 has a recording/playback connector of DIN type, connect it to the TAPE REC/P.B. CONNECTOR (25) of the SX-440. Disregard "CONNECTION FOR RECORDING" and "CONNECTION FOR PLAYBACK".

CONNECTION OF CARTRIDGE TAPE PLAYER

When using the cartridge tape player (PIONEER's Model H-60E), connect its output to the AUXILIARY TERMINALS (21). The connecting procedure is similar to that for record player connection.

RECEPTION OF BROADCAST

■ BEFORE TURNING ON THE POWER SWITCH OF THE SX-440, CHECK THE FOLLOWING:

VOLUME CONTROL KNOB (14) is set to "MIN".
TAPE MONITOR SWITCH (12) is set to "OFF".
MODE SWITCH (11) set to "STEREO".
SPEAKER ON/OFF SWITCH (7) is set to "ON".
(If using a stereo headphone, set the switch to "OFF").

■ RECEPTION OF FM BROADCAST:

1. Set the SELECTOR knob (5) to the "FM STEREO" position.
2. While observing the pointer deflection of the TUNING INDICATOR (2), tune the SX-440 to the desired station by using the TUNING knob (4). The best reception is attained when the pointer of the TUNING INDICATOR (2) largely deflects rightward. If the tuned station is broadcasting a stereo program, the STEREO INDICATOR (3) lights. With the SELECTOR knob (5) in this position, monaural programs can also be received.
3. When the desired station is tuned in, gently turn the VOLUME CONTROL knob (14) clockwise. Adjust the BASS CONTROL (9) and TREBLE CONTROL (10) for the desired tone quality.
 - When the SX-440 is used very afar from the broadcasting station, or external noise is intensive, the noise is suppressed and better reception is attained by setting the SELECTOR knob (5) to the "FM MONO" position. When the knob is in this position, however, stereo programs are received as monaural programs. (The stereo indicator is unrelated although it lights.)
4. When good radio reception cannot be attained by the above operating procedures 1 to 3, re-consider the antenna, referring to the article "ANTENNA CONNECTION AND GROUNDING".

■ RECEPTION OF AM BROADCAST:

1. Set the SELECTOR knob (5) to the "AM" position.
2. While observing the pointer deflection of the TUNING INDICATOR (2), tune the SX-440 to the desired station by using the TUNING knob (4). The best reception is attained when the pointer of the TUNING INDICATOR (2) largely deflects rightward.
3. When the desired station is tuned in, adjust the VOLUME CONTROL (14), BASS CONTROL (9) and TREBLE CONTROL (10) for desired sound volume and tone quality.
4. When good radio reception cannot be attained, such as speaker sound is noisy or inferior in tone quality by the above operating procedures 1 to 3, re-consider the antenna, referring to the article "ANTENNA CONNECTION AND GROUNDING". When the SX-440 is used very near the broadcasting station, the field intensity is sometimes too strong, resulting in low tone quality. If this occurs, shorten or remove the antenna connected to the AM antenna terminal for the best radio reception.



PLAY OF DISK RECORD

1. Set the SELECTOR knob (5) to the "PHONO" position. If the record player used a crystal or ceramic cartridge, set the knob to the "AUX" position.
2. When using a monaural record player, set the MODE SWITCH (11) to the "MONO" position.
3. Adjust the VOLUME, BASS and TREBLE CONTROLS for desired sound volume and tone quality.

PLAY OF CARTRIDGE TAPE

1. Set the SELECTOR knob (5) to the "AUX" position.
2. The succeeding procedure is similar to its counterpart of the disk record player operation.

RECORDING AND PLAYBACK WITH TAPE RECORDER (OR TAPE DECK)

■ RECORDING:

The same signals as those emitted from loudspeakers can always be taken out from the tape recording terminals (24) of the SX-440. Operate the selector knob (5) and mode switch (11) according to the program source to be recorded, following the instructions described in articles "RECEPTION OF BROADCAST" and "PLAY OF DISK RECORD"

The volume, bass and treble controls of the SX-440 cannot be used for the tape recording. The recording level should be adjusted by the control of the tape recorder (or tape deck).

NOTE: When using a monaural tape recorder, signals of either left or right channel only can be recorded.

■ PLAYBACK:

Set the TAPE MONITOR SWITCH (12) to the "ON" position. Adjust the VOLUME, BASS and TREBLE CONTROLS for desired sound volume and tone quality.

• When the TAPE MONITOR SWITCH (12) is in the "ON" position, the position of the SELECTOR knob (5) is unrelated to the playback operation.

■ TAPE MONITOR:

If the tape recorder used with the SX-440 is provided with a monitor circuit, monitor can be effected regardless of the tape recorder being two-head or three-head type. Connect the tape recorder to the SX-440 recording and playback terminals. By setting the TAPE MONITOR (12) from "OFF" to "ON" while making recording, the signals applied to the recording head can be monitored if the tape recorder is of the two head system. If a three-head tape recorder is used, recorded signals can be monitored immediately after recording.

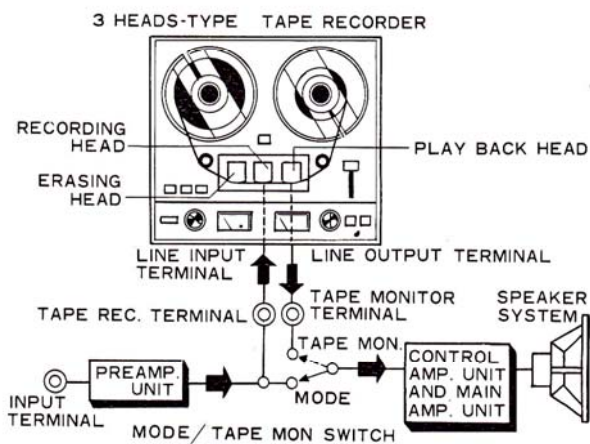

Fig. 12

PIONEER

ALIGNMENT INSTRUCTION

Please read these instruction with extreme care before attempting alignment.

* Test Equipment.

1) Standard Signal Generator. 2) VTVM, DC, AC 3) Oscilloscope.

* Attention on Alignment.

1) Signal Generator Input: Always use the minimum generator input that provides a satisfactory output indication.

2) When connecting the test equipment to the input, use a shielded wire that is as short as possible.

ALIGNMENT OF AM SECTION

* VTVM and oscilloscope should be connected in parallel at the output.

Position of Switch: SELECTOR AM

Volume Control Setting: Fully counterclockwise

Step	Input			Dial Setting	Output Equipment Connections	Alignment	
	Equipment Connections	Frequency	Level			Adjust	Remarks
1	Sweep generator Antenna terminal through dummy	455kHz	50dB	Point of no interference as near as 535kHz	VTVM Oscilloscope Ⓟ	T209 T207 T208	Adjust for maximum sensitivity and symmetrical characteristics.
2	Signal generator to antenna terminal through dummy	600kHz	30dB	600kHz	"	T205	Adjust for maximum deflection.
3	"	1,400kHz	"	1,400kHz	"	CT	"
4	Repeat steps 2 and 3 several times.						
5	Signal generator Antenna terminal through dummy	600kHz	30dB		VTVM Oscilloscope Ⓟ	Ferrite Antenna (Adjusting core)	Adjust for maximum deflection.
6	"	1,400kHz	"	1,400kHz	"	CT205	"
7	Repeat steps 5 and 6 several times.						

DIAL CORD STRINGING

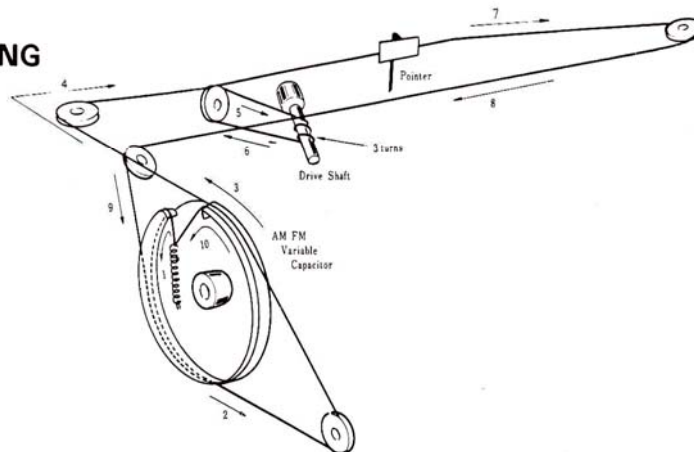



ALIGNMENT OF FM SECTION

Position of Switch: SELECTOR FM MONO

Volume Control Setting: Fully counterclockwise

Disconnect TP₂₀₁ from TP₂₀₂

STEP	Input			Dial Setting	Output Equipment Connections	Alignment	
	Equipment Connections	Frequency	Level			Adjust	Remarks
1	Sweep generator to FM antenna terminal.	10.7MHz	70dB	Point of no interference as near as 87MHz	Oscilloscope TP ₂₀₁	T ₂₀₁ , T ₂₀₂ , T ₂₀₃ , Primary of T ₂₀₄	Adjust for maximum sensitivity and symmetrical characteristics.
2	"	"	100dB		"		Check symmetry of characteristic curve.
3	"	"	70dB		Oscilloscope TP ₂₀₃	T ₂₀₄	Adjust the primary core of T ₂₀₄ so that slope of straight portion of "S" curve will become the steepest and adjust the secondary core so that the center of "S" curve will coincide with the center of the marker.
4	Connect TP ₂₀₁ to TP ₂₀₂						
5	Signal generator to FM antenna terminal.	90MHz	20dB (400Hz, 30%)	90MHz	VTVM Oscilloscope TP ₂₀₃	L ₂₀₄	Adjust for maximum deflection.
6		106MHz	"	106MHz	"	CT ₂₀₃	"
7	Repeat steps 5 and 6 several times.						
8	Signal generator to FM Antenna terminal.	90MHz	20dB (400Hz, 30%)	90MHz	VTVM Oscilloscope TP ₂₀₃	L ₂₀₁ L ₂₀₂	Adjust maximum deflection.
9	"	106MHz	"	106MHz	"	CT ₂₀₁ CT ₂₀₂	"
10	Repeat steps 8 and 9 several times.						

ALIGNMENT OF MPX SECTION

Position of Switch: SELECTOR FM STEREO

Volume Control Setting: Fully counterclockwise

Input Signal: Main (L + R) 40.5 kHz deviation (60%)
19 kHz Pilot 7.5 kHz deviation (10%)

STEP	Circuit to be adjusted	Input		Connect VTVM	Alignment	
		Connections	Signal		Adjust	Remarks
1	19kHz and 38kHz stages	MPX Generator to FM Antenna terminal	19kHz	AC VTVM TP ₂₀₅	T ₂₀₉ T ₂₁₀	Adjust for maximum deflection.
2	Separation Control	"	L or R	AC VTVM 2 or 3	T ₂₁₀	Adjust for minimum deflection of the other channel.
3	Repeat steps 1 and 2 several times.					

PIONEER

MODEL SX-440 TECHNICAL SPECIFICATIONS

• TRANSISTORS AND DIODES

Tuner Section	
F.E.T.	1
Transistors	11
Diodes	17
Audio Section	
Transistors	20
Diodes and etc.	6

• AUDIO SECTION

Circuitry	Single ended push-pull
Music Power Output	4 Ω 40 watts total (IHF rating) 8 Ω 33 watts total (IHF rating)
RMS Rated Power Output	4 Ω 15 watts per channel (both channels driven) 8 Ω 12 watts per channel (both channels driven)
Harmonic Distortion	Less than 1% (at 1kHz rated output)
Frequency Response	3dB, from 20 Hz to 70 kHz (overall)
Power Bandwidth	30 Hz to 20 kHz (AUX)
Hum & Noise (at rated output)	MAG: better than 75 dB AUX: better than 85 dB
Inputs and Audio Sensitivity (for rated output)	MAGnetic PHONO: 3 mv. TAPE MONITOR: 130 mv. AUXiliary: 130 mv.
Output Terminals and Jacks	Speakers: 4 to 16 ohms. Stereo headphones jack. Simultaneous tape Recording jacks, equipped with TAPE MONITOR switch. Tape recording/playback jack (DIN standards)
Equalization Curve	PHONO: RIAA
Tone Controls (each channel)	BASS: boost 13dB, cut 11 dB (at 50 Hz) TREBLE: boost 9.5 dB, cut 10 dB (at 10 kHz)
Loudness Contour	Switchable to ON-OFF. Boost 12 dB at 50 Hz, boost 6 dB at 10 kHz, with VOLUME control set at -40 dB

• FM SECTION

Circuitry	Front end using "F.E.T." and 3 gang variable capacitor.
Frequency Range	87 - 108 MHz.
IHF Usable Sensitivity	2.5 μ V
Image Rejection	55 dB (at 98 MHz.)
Signal-to-noise Ratio	50 dB (IHF rating)
Antenna Input	300 ohms (balanced)

• MULTIPLEX SECTION

Circuitry	Time-switching type demodulator. FM mono/stereo automatic selection
Channel Separation	35 dB (at 1 kHz.)

• AM SECTION

Circuitry	Superheterodyne
Frequency Range	525 - 1605 kHz.
IHF Usable Sensitivity	8 μ V
Image Rejection	47 dB (at 1000 kHz.)
Antenna Input	Built in ferrite loopstick antenna

• POWER SUPPLY, ETC'

Line Requirements	110, 117, 130, 220, 240 volts, (switchable), 50/60 Hz. 80 watts (max.)
Dimensions	Overall 15-15/16"/405mm (width) 5-7/16"/139mm (height) 15" /358mm (depth)
Weight	Without Package 17lbs. 7.7kg With Package 20lbs. 8 oz. 9.3kg



CONDITIONS FREQUENTLY MISTAKEN TO TROUBLES

Noise: There are a variety of noises relating to the operation of a hi-fi unit. These are generally divided into two types; (1) the unit is faulty (a transistor or part is deteriorated) and (2) an external source of noise gives noise to the unit.

When a hi-fi unit produces an unpleasant noise, it is often judged that the unit is faulty, but statistical records indicate that the majority of noises produced in a hi-fi acoustic units result from external sources of noise. Due to the inherent high sensitivity

and the high fidelity in reproduction, the unit amplifies and reproduces extraneous noises, however small, into definite output noise. If your receiver produces a noise, check according to the following table and trace out the source of noise for an appropriate corrective action.

The table includes the conditions that may be mistaken to troubles of the unit.

	Symptom	Suspected Source of Noise	Diagnosis and Remedy
When Listening to Broadcasts	Continuous or intermittent noise like jjjjjj or zzzzzz.	<ul style="list-style-type: none"> • Statics or listening. • Fluorescent lamp, motor, or thermostat may be used in house or in the vicinity of the house. 	In many cases, it is very difficult to remove the source of noise. In order to increase the radio input larger than the noise level, set up a good outdoor antenna and make a complete grounding.
	When a station is tuned in, hum is mixed in the program.	<ul style="list-style-type: none"> • Poor fluorescent lamp, motor, or electric heater may be used in house or near the house. 	Reversing the line plug may occasionally alleviate this noise problem. Usually it is very difficult to eliminate the noise.
	Hissing sound noise in AM (medium wave) reception.	<ul style="list-style-type: none"> • The frequency of an adjacent station is interfering with that of the station being tuned in (10kHz beat interference). • TV set is on in the same house where the receiver. 	Impossible to remove such interference. If the cause of such noise is in the TV set, increase the distance between the TV set and receiver.
	Static noise in FM reception (in particular, when automobiles run close to the house).	<ul style="list-style-type: none"> • White noises generated from automobile engines. • Radio frequency sewing machine or welding machine being used near your house. 	In an area surrounded by hills or high buildings, the FM input signals are very weak. Thus the noise limiter in the circuit loses its function. Set up an outdoor FM antenna having many reflector elements.
When Playing Records	Reception of FM stereo program contains more noise than FM mono program.	<ul style="list-style-type: none"> • Note that the service area covered by an FM stereo broadcast is about 50 % that of a regular mono broadcast. 	Increasing FM input signal may alleviate this problem. Use an exclusive FM outdoor antenna instead of the indoor T-antenna.
	Hum or buzz. When switched to radio reception, the noise will disappear.	<ul style="list-style-type: none"> • Poor connection of shielded wire (a). • Jack connection is loose. (b) • Line cord or fluorescent lamp is near the shielded wire. (c) • Poor grounding. (d) • HAM transmitting station or TV transmitting station is near your house. (e) 	Correct the conditions stated in (a), (b), (c) or (d). In case of (e), report it to an official activity.
	Output tone quality is poor and mixed with noise. Treble is not clear.	<ul style="list-style-type: none"> • Stylus is worn out. (a) • Record is worn out. (b) • Dust adheres to stylus. (c) • Improper mounting of stylus. (d) • Stylus pressure is not proper. (e) • The TREBLE sound level is too high. 	Check (a) through (e) and correct the condition. Lower the TREBLE level. Lower the TREBLE level.

Further, watch the following conditions: These are also apt to be mistaken to troubles of the unit.

	Symptom	Suspected Source of Noise	Diagnosis and Remedy
	Power is not turned on although the power switch is set to ON.	<ul style="list-style-type: none"> • Fuse is blown. (a) • Line plug is loose. (b) 	Check (a) and (b) and correct the condition.
	In playing a record, increasing the volume will cause howling.	<ul style="list-style-type: none"> • Distance between the record player and the speakers is too short. • The place on which the record player or speakers is unstable. 	Change the distance or rearrange the installation positions of the unit and speakers. (Installing the record player on a firm, solid stand may alleviate this problem.) Do not enhance the BASS sound level excessively.

PARTS LIST OF THE SX-440

CAPACITORS IN μF , 10% TOLERANCE UNLESS OTHERWISE NOTED
P: $\mu\mu\text{F}$

Symbol	Description			Part No.
C1	Ceramic	0.01		DC1.4KV C43-003-0
C2	"	"		"
C3	Electrolytic	1000		35V C52-046-A
C4	"	100		10V
C5	Ceramic	180P		50V
C6	"	"		"
C7	Mylar	0.02	$\pm 20\%$	"
C8	"	"	"	"
C9	Electrolytic	1000		16V C51-021-0
C10	"	"		"
C11	Mylar	0.1	$\pm 20\%$	50V
C12	"	"	"	"
C13	Ceramic	0.01		DC1.4KV C43-003-0

RESISTORS

IN OHMS, 10% TOLERANCE UNLESS OTHERWISE NOTED
K: $\text{K}\Omega$ M: $\text{M}\Omega$

Symbol	Description			Part No.
R2	Carbon Film	15K		$\frac{1}{4}$ W
R3	"	"		"
R4	"	22K		"
R5	"	"		"
R6	Wire Wound	0.5		2W
R7	"	"		"
R8	"	"		"
R9	"	"		"
R10	Carbon Film	10		$\frac{1}{4}$ W
R11	"	"		"
R12	"	100		"
R13	"	"		"
R14	"	22		"

DIODE AND TRANSISTORS

Symbol	Description	Part No.
D1	SD-1yz Diode	
Th1	D-22A Thermister	
Th2	"	
Q1	2SD226 or 2SD130 Transistor	
Q2	"	
Q3	"	
Q4	"	

COIL AND TRANSFORMERS

Symbol	Description	Part No.
L1	AM Ferrite Loopstic Antenna	T42-022-B
T1	Power Transformer	T52-157-0
T2	Matching Transformer	T61-041-0
T3	"	"

POTENTIOMETERS

Symbol	Description	Part No.
VR1	250K dual, Volume	C87-021-0
VR2	100K dual, Bass	C82-033-0
VR3	100K dual, Treble	"

SWITCHES

Symbol	Description	Part No.
S1	Input Selector	S13-021-B
S2	Power Switch	S11-016-A
S3	Toggle Switch	S42-002-A
S4	"	"
S5	"	"

S6	Toggle Switch	S42-022-A
S7	"	"
S8	Line Voltage Selector	S11-018-0

MISCELLANEOUS

Symbol	Description	Part No.
	AF Unit	W15-073-A
	Tuner Unit	W35-007-0
	Power Supply Unit	W16-021-0
	Front Panel	M21-267-0
	Plustics Panel	M21-271-0
	Wooden Case	M33-086-D
	Screw, to fix Wooden Case	B11-022-B
	Dial Pulley, for Tuning Capacitor	M42-018-E
	Dial Pulley	M42-009-B
	Dial Glass	A33-074-0
	Dial Pointer	A31-087-0
	Foot	M61-017-0
	Tuning Meter	A91-007-0
	Knob, Bass, Treble, Power	A12-131-0
	Knob, Volume (L)	A12-134-0
	Knob, Volume (R)	A13-013-0
	Knob, Selector	A12-136-0
	Knob, Tuning	A12-139-0
	Pilot Lamp	E22-012-0
	"	E22-015-0
	Pilot Lamp socket	K41-002-B
	Fuse 0.5A	E21-007-0
	Fuse 1A	E21-004-0
	Fuse 2A	E21-005-0
	Fuse Holder 2p	K92-006-0
	Head phone Jack	K72-021-B
	Connector 5p	K93-003-B
	Plug for Speaker	K72-007-B

(Metal Cover M33-086-D
SX-440 (E) Only)

POWER SUPPLY UNIT (W16-021)

CAPACITORS

Symbol	Description			Part No.
C101	Electrolytic	100		25V
C102	"	10		"
C103	"	100		15V
C104	Ceramic	0.01	$+80\%$ -20%	D.C 1.4KV C43-003-0
C105	"	"	"	"

RESISTORS

Symbol	Description			Part No.
R101	Carbon film	390		1/4
R102	"	10K		"
R103	"	22K		"
R104	"	150		"
R105	"	3.3K		"

DIODES AND TRANSISTORS

Symbol	Description	Part No.
D101	1S337 Zener Diode	
D102	SD-1y Diode	
D103	"	
Q101	2SC968Y Transistor	
Q102	"	

TUNER UNIT(W35-007)

CAPACITORS

Symbol	Description			Part No.
C201	Ceramic	10p	± 0.5p	50V
C202	"	0.001	+100%	"
C203	"	0.01	"	"
C204	"	"	"	"
C205	"	15p	± 0.5p	"
C206	"	0.01	+100%	"
C207	"	10p	± 0.5p	"
C208	"	100p	"	"
C209	"	1p	± 0.5p	"
C210	"	0.01	+100%	"
C211	"	"	"	"
C212	"	2.2p	"	500V
C213	"	0.04	+100%	50V
C214	"	0.01	"	"
C215	"	390p	"	"
C216	"	5p	± 0.5p	"
C217	"	2p	"	"
C218	"	0.04	+100%	"
C219	"	390p	"	"
C220	"	3p	± 0.5p	"
C221	"	0.04	+100%	"
C222	Polystyrene	330p	"	"
C223	"	"	"	"
C224	"	820p	"	"
C225	Electrolytic	2.2	"	63V
C226	Ceramic	10p	± 0.5p	50V
C227	"	9p	"	"
C228	"	1p	"	"
C229	"	0.01	+100%	"
C230	"	"	"	"
C231	"	10p	± 0.5p	"
C232	"	0.01	+100%	"
C233	"	"	"	"
C234	"	"	"	"
C235	"	"	"	"
C236	"	"	"	"
C237	"	"	"	"
C238	"	"	"	"
C239	"	0.005	"	"
C240	"	0.01	"	"
C241	"	390p	"	"
C242	"	9p	± 0.5p	"
C243	"	0.005	+100%	"
C244	"	0.04	"	"
C245	Electrolytic	2.2	"	63V
C246	Ceramic	560p	"	50V
C247	"	0.04	+100%	"
C248	"	0.01	"	"
C249	"	"	"	"
C250	"	"	"	"
C251	"	390p	"	"
C252	"	0.005	+100%	"
C253	"	0.01	"	"
C254	"	"	"	"
C255	Electrolytic	2.2,	"	63V
C256	"	10	"	16V
C257	Ceramic	0.01	"	50V
C258	Electrolytic	100	"	16V
C259	"	2.2	"	63V
C260	Polystyrene	680p	5%	50V
C261	"	"	"	"
C262	"	"	"	"
C263	Electrolytic	47	"	16V
C264	Mylar	0.01	"	50V
C265	"	0.004	"	"
C266	Polystyrene	470p	"	"
C267	Electrolytic	33	"	16V
C268	Polystyrene	470p	"	50V
C269	Electrolytic	33	"	16V
C270	Polystyrene	180p	"	50V
C271	Mylar	0.02	"	"

C272	Mylar	0.02		50V
C273	"	"		"
C274	"	"		"
C275	"	0.015		"
C276	"	"		"
C277	"	0.1	± 20%	"
C278	"	"	"	"

RESISTORS

Symbol	Description			Part No.
R201	Carbon Film	100K		1W
R202	"	"		"
R203	"	1M		"
R204	"	470		"
R205	"	220		"
R206	"	22K		"
R207	"	"		"
R208	"	2.7K		"
R209	"	10K		"
R210	"	100		"
R211	"	15K		"
R212	"	22K		"
R213	"	1.2K		"
R214	"	120		"
R215	"	100		"
R216	"	680		"
R217	"	10		"
R218	"	1.2K		"
R219	"	470		"
R220	"	100		"
R221	"	1K		"
R222	"	2.2K		"
R223	"	6.8K		"
R224	"	"		"
R225	"	"		"
R226	"	2.7K		"
R227	"	22K		"
R228	"	"		"
R229	"	56		"
R230	"	1M		"
R231	"	"		"
R232	"	15K		"
R233	"	39K		"
R234	"	5.6K		"
R235	"	27K		"
R236	"	100		"
R237	"	1.5K		"
R238	"	100		"
R239	"	33		"
R240	"	22K		"
R241	"	68K		"
R242	"	27K		"
R243	"	100		"
R244	"	15K		"
R245	"	2.7K		"
R246	"	220K		"
R247	"	47K		"
R248	"	1.5K		"
R249	"	15K		"
R250	"	4.7K		"
R251	"	100		"
R252	"	220		"
R253	"	12K		"
R254	"	82K		"
R255	"	470		"
R256	"	3.9K		"
R257	"	15K		"
R258	"	39K		"
R259	"	680		"
R260	"	1.2K		"
R261	"	68		"
R262	"	5.6K		"
R263	"	100		"
R264	"	1.5K		"
R265	"	33K		"

R266	Carbon Film	33K	1/4W
R267	"	68K	"
R268	"	"	"
R269	"	6.8K	"
R270	"	"	"
R271	"	27K	"
R272	"	"	"

DIODES AND TRANSISTORS

Symbol	Description	Part No.
D 201	I S188 Diode	
D 202	"	
D 203	"	
D 204	"	
D 205	SD46R Diode	
D 206	"	
D 207	I S188 Diode	
D 208	I S85 Diode	
D 209	I S188 Diode	
D 210	"	
D 211	OA79 Diode	
D 212	SD46R Diode	
D 213	"	
D 214	I S188 Diode	
D 215	"	
D 216	"	
D 217	"	
Q 201	3SK-22 FET	
Q 202	2SC430 Transistor	
Q 203	2SC460 Transistor	
Q 204	"	
Q 205	"	
Q 206	2SC430 Transistor	
Q 207	2SC838 Transistor	
Q 208	2SC839 Transistor	
Q 209	"	
Q 210	"	
Q 211	"	
Q 212	2SC870 Transistor	

COILS AND TRANSFORMERS

Symbol	Description	Part No.
L 201	FM ANT Coil	T22-015-0
L 202	FM RF Coil	T21-015-0
L 203	RF Choke Coil	T24-028-0
L 204	FM OSC Coil	T23-036-A
L 205	Choke Coil	T75-005-0
L 206	"	T75-004-0
L 207	"	T75-006-0
T 201	FM IFT	T73-025-0
T 202	"	T73-026-0
T 203	"	"
T 204	"	T74-006-0
T 205	AM OSC Coil	T43-006-0
T 206	AM IFT	T71-024-0
T 207	"	"
T 208	"	T72-018-0
T 209	19KHz Transformer	T75-002-0
T 210	38KHz "	T75-003-A

AUDIO UNIT (W15-073) CAPACITORS

Symbol	Description			Part No.
C301	Electrolytic	3.3		25V
C302	"	"		"
C303	Mylar	0.02		50V
C304	"	"		"
C305	"	0.005		"
C306	"	"		"
C307	Electrolytic	10		10V
C308	"	"		"
C309	Mylar	0.1		50V
C310	"	"		"
C311	Electrolytic	220		25V
C312	"	"		"
C313	"	1		50V
C314	"	"		"
C315	"	3.3		25V
C316	"	"		"
C317	"	47		3V
C318	"	"		"
C319	Mylar	0.001		50V
C320	"	"		"
C321	"	0.0068		"
C322	"	"		"
C323	"	0.02		"
C324	"	"		"
C325	"	0.1		"
C326	"	"		"
C327	Electrolytic	3.3		25V
C328	"	"		"
C329	" (Non polar)	30		10V
C330	" (Non polar)	"		"
C331	"	47		3V
C332	"	"		"
C333	"	22		25V
C334	"	"		"
C335	Mica	100p		150V
C336	"	"		"
C337	Electrolytic	47		3V
C338	"	"		"
C339	Mica	300p		150V
C340	"	"		"
C341	Electrolytic	220		25V
C342	Mica	10p		50V
C343	"	"		"

RESISTORS

Symbol	Description			Part No.
R301	Carbon film	1K	1/4	
R302	"	"	"	
R303	"	100K	"	
R304	"	"	"	
R305	"	"	"	
R306	"	"	"	
R307	"	390	"	
R308	"	"	"	
R309	"	150K	"	
R310	"	"	"	
R311	"	5.6K	"	
R312	"	"	"	
R313	"	1K	"	
R314	"	"	"	
R315	"	2.2K	"	
R316	"	"	"	
R317	"	330K	"	
R318	"	"	"	
R319	"	15K	"	
R320	"	"	"	
R321	"	5.6K	"	
R322	"	4.7K	"	
R333	"	330K	"	
R324	"	"	"	
R325	"	56K	"	
R326	"	"	"	
R327	"	4.7K	"	
R328	"	"	"	
R329	"	1K	"	
R330	"	"	"	
R331	"	"	"	
R332	"	"	"	
R333	"	15K	"	
R334	"	"	"	
R335	"	3.9K	"	
R336	"	"	"	
R337	"	12K	"	
R338	"	"	"	
R339	"	220K	"	
R340	"	"	"	
R341	"	22K	"	
R342	"	"	"	
R343	"	6.8K	"	
R344	"	4.7K	"	
R345	"	"	"	
R346	"	470	"	
R347	"	"	"	
R348	"	150	"	
R349	"	"	"	
R350	"	1K	"	
R351	"	"	"	
R352	"	68K	"	
R353	"	"	"	
R354	"	4.7K	"	
R355	"	"	"	
R356	"	"	"	
R357	"	"	"	
R358	"	150	"	
R359	"	"	"	
R360	"	220	"	
R361	"	"	"	
R362	"	22	"	
R363	"	"	"	
R364	"	220	"	
R365	"	"	"	
R366	"	15K	"	
R367	"	"	"	

TRANSISTORS

Symbol	Description	Part No.
Q301	2SC871 BL Transistor	
Q302	"	
Q303	2SC870 BL Transistor	
Q304	"	
Q305	"	
Q306	"	
Q307	"	
Q308	"	
Q309	2SC734-R Transistor	
Q310	"	
Q311	2SC734-P Transistor	
Q312	"	
Q313	2SA561-P Transistor	
Q314	"	

NOTE

- The circuit diagram and parts list of this receiver has been changed as follows.

R245	2.2K	
R262	4.7K	
Q209	2SC838	Transistor
Q210	"	"
Q211	"	"
C279	Ceramic 15P	(addition)

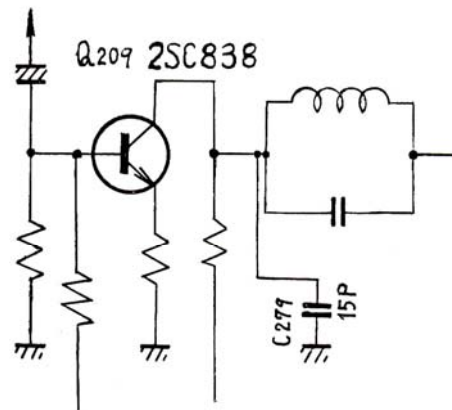

PRINTED CIRCUIT BOARD

TUNER UNIT (W35-007)

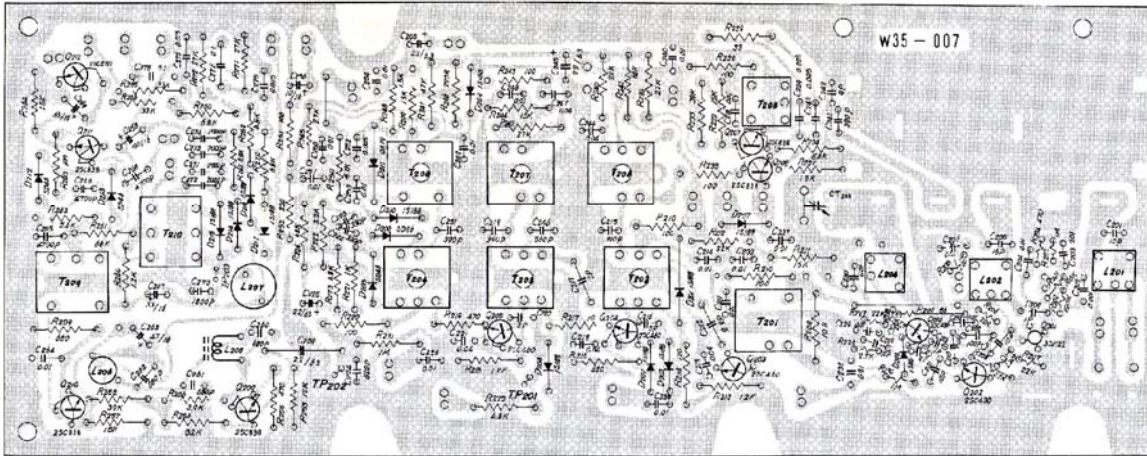

AUDIO UNIT (W15-073)

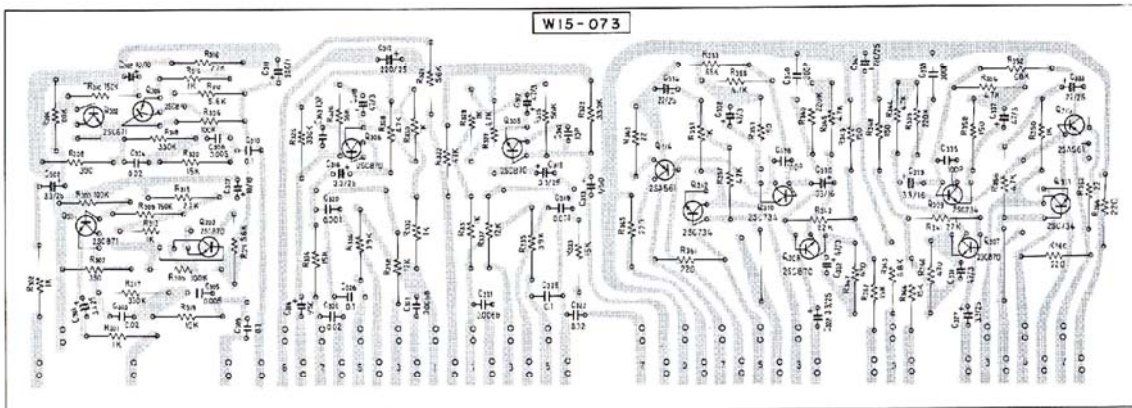

POWER SUPPLY UNIT (W16-021)

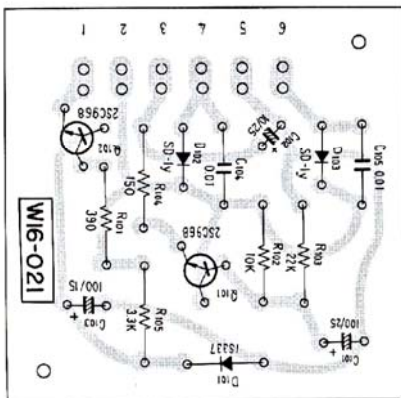

PIONEER

PARTS LAYOUT (Top View)

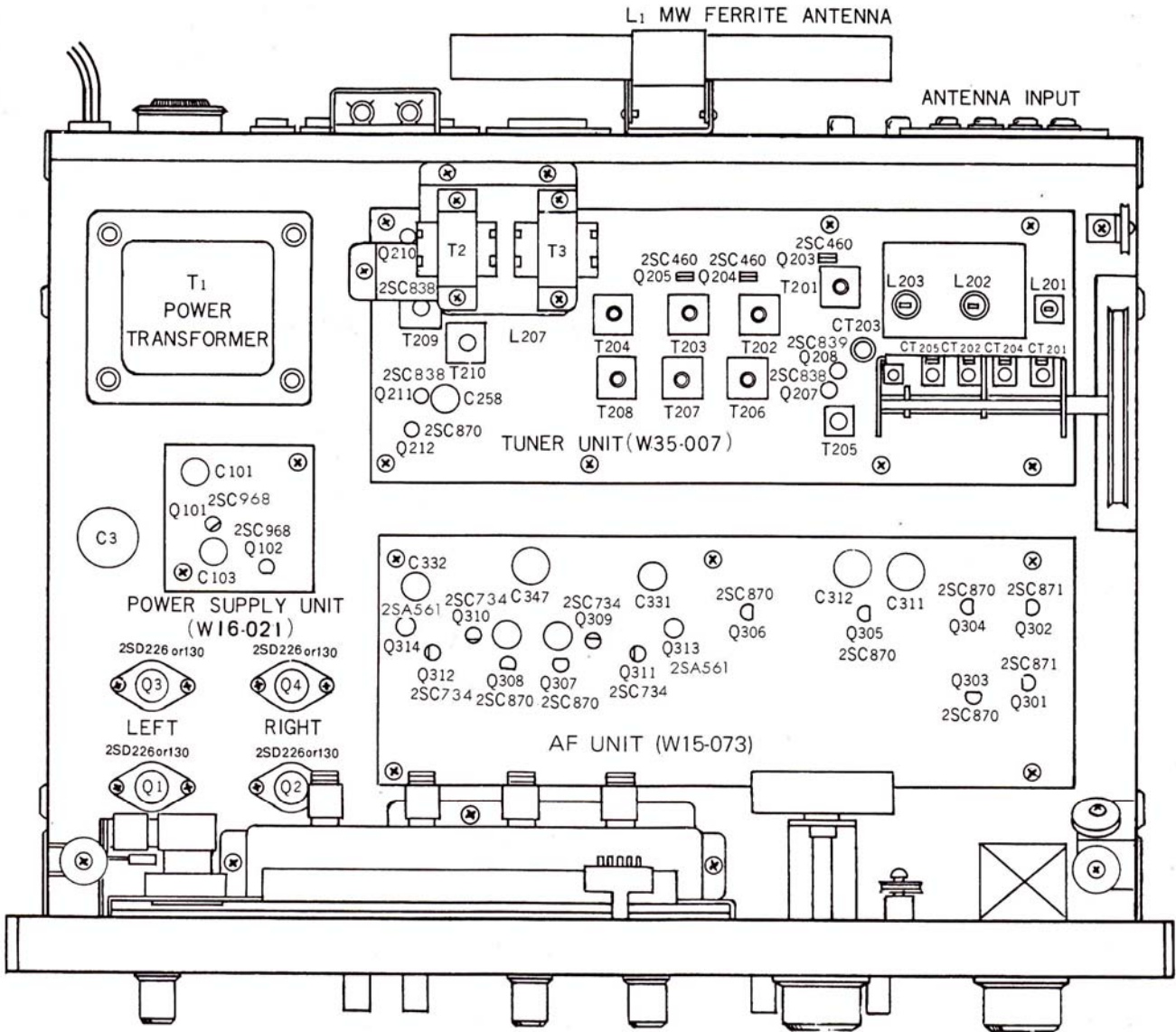

PIONEER ELECTRONIC CORPORATION

15-5, 4-Chome, Ohmori-nishi, Ohta-ku, Tokyo, Japan

PIONEER ELECTRONICS U.S.A. CORPORATION

140 Smith St., Farmingdale, L.I., N.Y. 11735, U.S.A.

PIONEER ELECTRONIC (EUROPE) AG.

59, Forch Strasse, 8032 Zurich, Switzerland